



**Family of compact
timers... 1/8 DIN
housing mounts in
standard relay socket**



The DG100 is a solid state timer housed in a 1/8 DIN, molded NORYL® case. The timer uses CMOS integrated circuits for the timing function. The DG100 series timer is available in 16 time ranges from 3.5 seconds to 30 hours. Time is set with a knob referenced to a graduated scale. A pilot light on the front of the unit indicates when the unit is timing.

- All connections make through standard square base relay socket
- Available accessories for conversion into panel mount including a version with plug-in capability
- Standard unit functions as ON-Delay timer in sustained start mode
- Single relay with isolated double pole - double throw relay contact controls outputs
- Timer operation can be configured as: interval output timer with momentary start; repeat cycle timer with pulse output; or repeat cycle timer with equal ON and OFF periods

OPERATION

The timing base for the DG100 series timer is generated by an internal oscillator set by a precision capacitor and a dial adjustable potentiometer. This technology allows accurate control over long time ranges.

The unit times as long as power is applied to the control input terminal. The output contacts change state at the completion of the timing period. The unit resets when power is removed from the control input. Specific status details are found in the operational mode section of the product bulletin.

SPECIFICATIONS

Time Ranges:

Sym.	Dial Range	Minimum Setting	Sym.	Dial Range	Minimum Setting
01	3.5 Sec.	.35 Sec.	09	15 Min.	1.5 Min.
02	7 Sec.	.7 Sec.	10	30 Min.	3 Min.
03	15 Sec.	1.5 Sec.	11	60 Min.	6 Min.
04	30 Sec.	3 Sec.	12	120 Min.	12 Min.
05	60 Sec.	6 Sec.	13	4 Hr.	.4 Hr.
06	120 Sec.	12 Sec.	14	8 Hr.	.8 Hr.
07	4 Min.	.4 Min.	15	15 Hr.	1.5 Hr.
08	8 Min.	.8 Min.	16	30 Hr.	3 Hr.

Operating Voltage/Frequency:

120 VAC (+10 -15%), 50/60 Hz or 120 VDC (+10 -15%)
240 VAC (+10 -15%), 50/60 Hz or 240 VDC (+10 -15%)
24 VAC (+10 -15%) 50/60 Hz or 24 VDC (+10 -15%)

Setting Accuracy: Within ±10% of maximum range

Repeatability (Constant Voltage & Temperature):
±0.1% of setting or 25 ms, whichever is larger

Repeatability (Voltage & Temperature Variation):
Variable Voltage: ±1% of setting
Variable Temperature: ±2% of setting
Variable Voltage and Temperature: ±3% of setting

Reset Time: 50 ms

Cycle Progress: Pilot light during timing

Burden:	OFF Time	On Time
120 VAC or DC	.8 VA max.	4.8 VA max.
240 VAC or DC	1.6 VA max.	4.8 VA max.
24 VAC or DC	1.5 VA max.	2.9 VA max.

Power on Response: 30 ms max. after line voltage applied to pins A and B

Operating Temperature: 0° to -60°C (+32° to +140°F)

Output Rating:

Relay: 10 amp steady state, 120 VAC
Mechanical Life: over 20 million operations
Electrical Life: contingent upon load characteristics

Power Interruption:

Line voltage interruptions of 20 ms or less will not reset unit

Transient Voltage Immunity: Unaffected by 50 microseconds, 600 V peak transients superimposed on the line input

Vibration: Unit function is unaffected by 2.5G sinusoidal vibration magnitude in both directions of three perpendicular mounting axes imposed from 10 to 100 Hz

Agency Approvals:

UL Recognition E96337
CSA Certification L26861
FM Approved J10C8A4.AF

OUTPUT OPERATING MODES

ON-Delay

The unit starts timing when voltage is applied to terminals A and B. When the dial setting is reached, the output relay energizes and remains in the energized state as long as voltage is applied to terminals A and B. Removal of voltage from terminals A and B resets the unit.

Interval

The unit starts timing with the input relay in the energized state when voltage is applied to terminals A and B. When the dial setting is reached, the output relay deenergizes and remains in that state until voltage is reapplied to terminals A and B. Removal of voltage from terminals A and B resets the unit.

Repeat Cycle Pulse Output

The unit starts timing when voltage is applied to terminals A and B. The output relay is deenergized during timing. When the dial setting is reached, the output is energized for 200 ms typical. After the pulse, the unit starts timing for the next cycle. The cycle continues until voltage is removed from terminals A and B.

DG100 TERMINAL ASSIGNMENTS

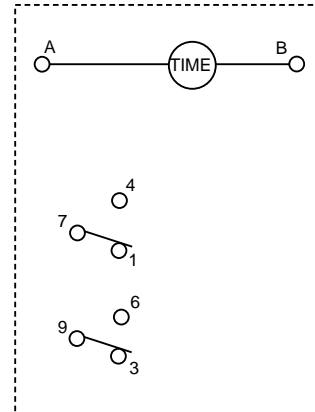

MOUNTING

Panel Mount:

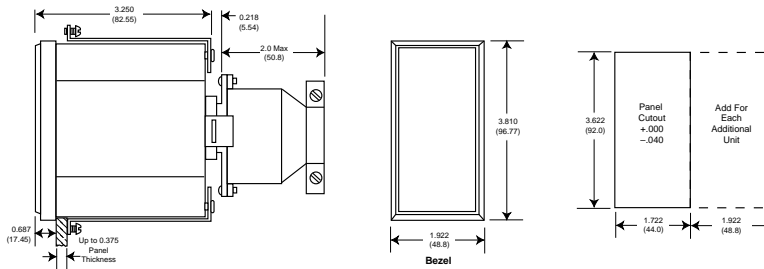

Surface Mount:

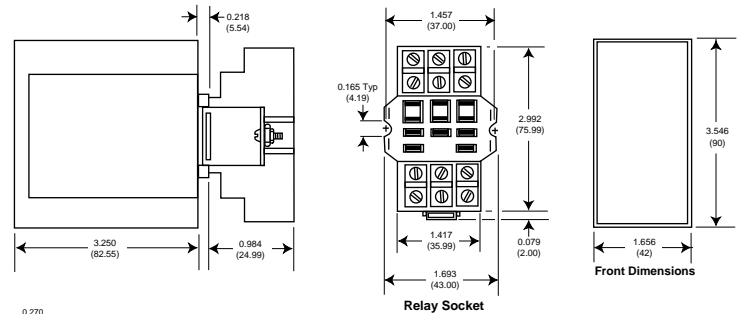

Plug-In Mount:

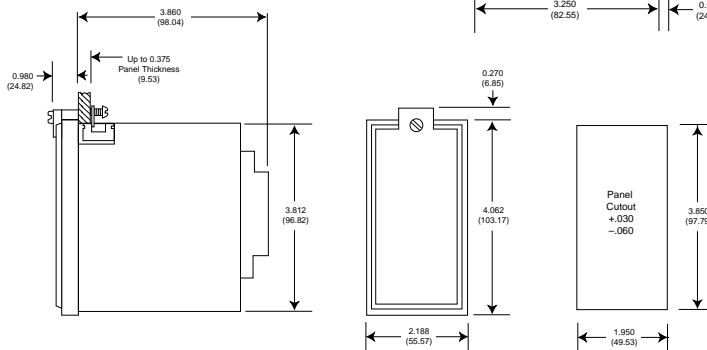

ORDERING INFORMATION

TIME RANGE

See Specifications for Time Range Catalog Symbol

DG1 **03** **A3** **02**

VOLTAGE & FREQUENCY

Sym.	Description
A3	120 VAC, 50/60 Hz or 120 VDC
B3	240 VAC, 50/60 Hz or 240 VDC
Z3	24 VAC, 50/60 Hz or 24 VDC

FEATURES

Sym.	Description
(Blank)	Standard, On-Delay, DPDT Relay Output
02	Interval Timing (Momentary Start)